

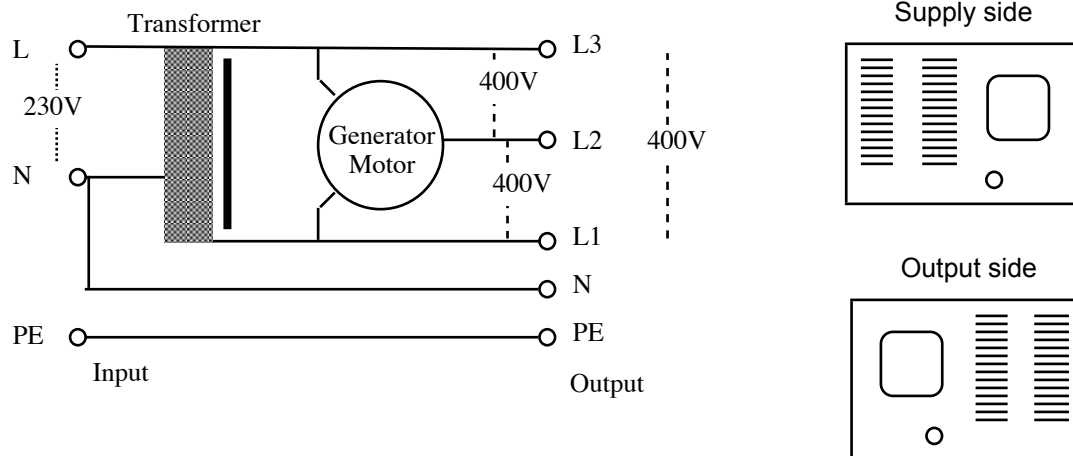

30/01/2020

## Connecting a Booster C



### Connect a Booster™:

Position a Booster™ close to the power source to prevent losses on the supply line. Use a motor-rated d-curved protective circuit breaker or fuse in your fuse box. 20A for 4kW or 40A for 8kW. Install a single-phase wall switch or switch-socket combination near the converter.

### Danger:

Never run a Booster without a cover, voltages inside are up to 1600V peak. Before opening, disconnected from power and wait for at least for ten minutes. Resistors require time to fully discharge capacitors. Measure before touching anything.

### Connect a machine:

Disable Star Delta starters in machines, they can produce high energy and damage a converter. Remove the two wire bridges on the star contactor.

Connect control transformers in machines to these converter's output phases:

Machines with a five pin plug (a 230V control transformer): L3 and N.

Machines with a four pin plug (a 400V control transformer): L3 and L1.

Find the phases the transformer is connected to by measuring resistance on the plug.

### Internal heaters:

Connect a 230V heater element inside a machine directly to a single phase supply, not to a converter's output. Example: Edge banders.

Voltages between L1 and N and L2 and N are not 230V, do not use. Only L3 is 230V to Neutral. Use this for control purposes only.